

Anna and the Barbies stage plot

Inputs

- 1. - Kick
- 2. - Snare - top
- 3. - Snare -bottom
- 4. - H/H
- 5. - rack - tom
- 6. - floor -tom
- 7. - ride
- 8. - over head
- 9. - Bass line I.
- 10. - Bass - line II.
- 11. - GTR- Left
- 12. - GTR - Right
- 13.-14. - HD lines
- 15.-16. - Lead lines
- 17.-18. - EFX lines
- 19. - GTR -Voc
- 20. - Lead Voc (wireless)
- 22. - Drum - Voc
- 23.-24. - Vocals lines

Outputs

- iem out: 1-2 - GTR (wireless)
- iem out: 3-4 - Lead Vocal (wireless)
- iem out: 5 - Bass (wireless)
- iem out: 8-9 - drum (wired)
- aux out:14 - P.A. sub
- aux out:15-16 - P.A. left -right

Other Items

- Drum riser 2m x 2m
- Power Outlet (7)
- drum monitor mixer
- HD





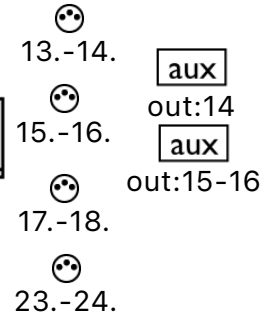
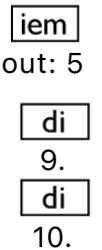
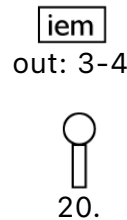
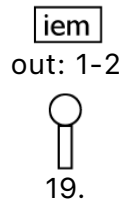
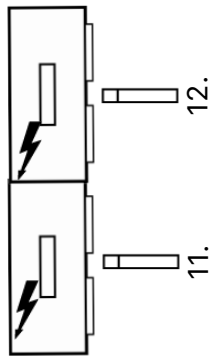
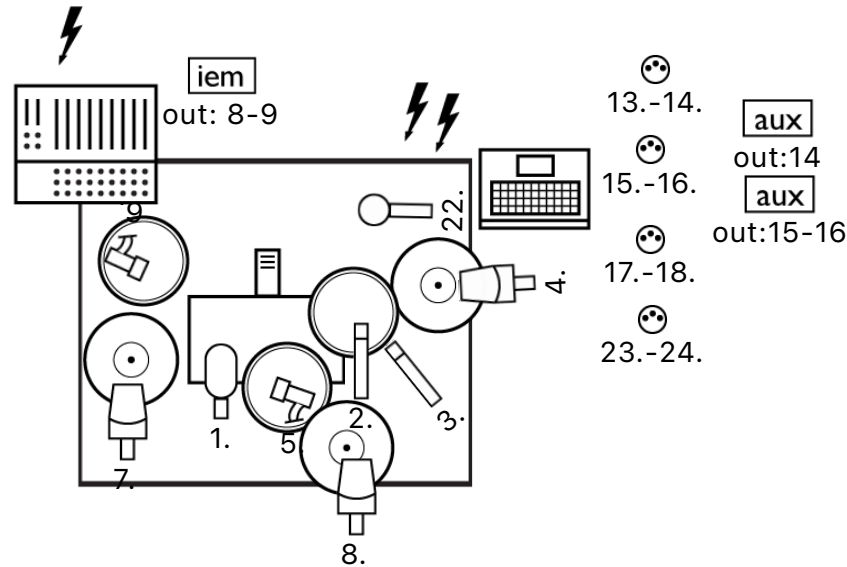





Contact Info

Pignon
 pignonapu@gmail.com
 +36703953927







AatB acoustic stage plot



Inputs

-  1.-kick - Kick Drum Mic
-  2. Snare -top - Clip Mic
-  3. snare- bottom - Clip Mic
-  4. H/H - Area Mic
-  5.-rack tom - Clip Mic
-  6. -floor tom - Clip Mic
-  7.-over left - Area Mic
-  8.-over right - Area Mic
-  09.Bass line I - XLR Input
-  10.Bass line II. - XLR Input
-  11.GTR left - DI Box
-  12.GTR right - DI Box
-  13. Key left - XLR Input
-  14. Key right - XLR Input
-  15. Piano - Instrument Mic
-  16.Piano - Instrument Mic
-  17. SPD -left - DI Box
-  18. SPD - right - DI Box
-  19.Simi vocal - Vocal Mic
-  20.Anna vocal - Vocal Mic
-  22.drums vocal - Vocal Mic

Outputs

-  1-2 Simi - In-Ear Monitor
-  3-4 Anna - In-Ear Monitor
-  5. Dávid - In-Ear Monitor
-  6-7 Tomi - In-Ear Monitor
-  8-9 Ádi - In-Ear Monitor

Other Items

-  Drum riser 2x2m
-  Riser
-  Power Outlet (5)

Contact Info

Pignon
 pignonapu@gmail.com
 +36703953927

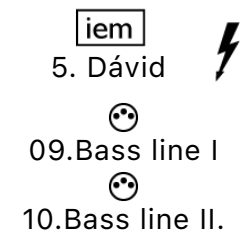
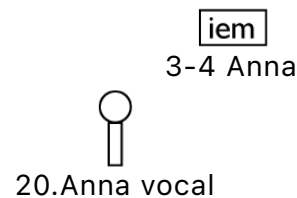
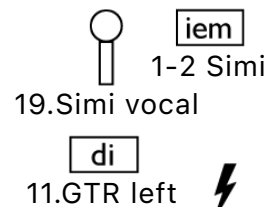
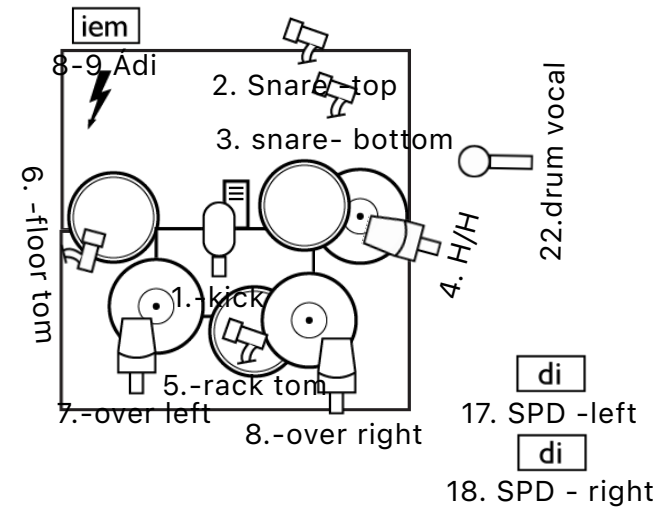
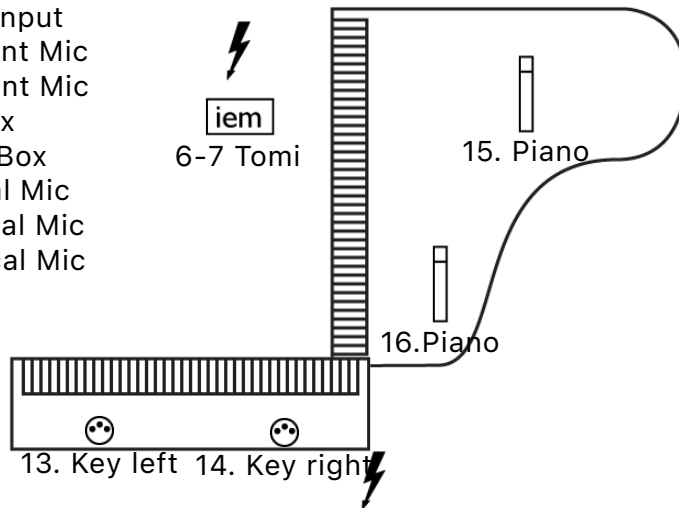

AatB theatrical technical rider

Inputs

- 1.-kick - Kick Drum Mic
- 2. Snare -top - Clip Mic
- 3. snare- bottom - Clip Mic
- 4. H/H - Area Mic
- 5.-rack tom - Clip Mic
- 6. -floor tom - Clip Mic
- 7.-over left - Area Mic
- 8.-over right - Area Mic
- 09.Bass line I - XLR Input
- 10.Bass line II. - XLR Input
- 11.GTR left - DI Box
- 12.GTR right - DI Box
- 13. Key left - XLR Input
- 14. Key right - XLR Input
- 15. Piano - Instrument Mic
- 16.Piano - Instrument Mic
- 17. SPD -left - DI Box
- 18. SPD - right - DI Box
- 19.Simi vocal - Vocal Mic
- 20.Anna vocal - Vocal Mic
- 21.guest vocal - Vocal Mic
- 22.drums vocal - Vocal Mic

Outputs

- 1-2 Simi - In-Ear Monitor
- 3-4 Anna - In-Ear Monitor
- 5. Dávid - In-Ear Monitor
- 6-7 Tomi - In-Ear Monitor
- 8-9 Ádi - In-Ear Monitor
- 10.side fill left - Fill Monitor
- 11.side fill right - Fill Monitor

Other Items

- Drum riser 2x2m
- Riser
- ⚡ Power Outlet (5)

